

High Bay Light Specification

HZ-GKD150WA



Features

- Phase change heat dissipation technology, keeping the junction temperature at 65°C
- Heat sink for passive cooling
- High efficiency Bridgelux multi-chips LED source
- Long life=Less maintenance
- LED life 50,000 hours
- Mean-well power supply
- Certified to Australian Standards

Phase Change Liquid Cooling Systems : The Hi-Semicon Advantage

Hi-Semicon's Phase Change Liquid Cooling system removes more heat than competitive technologies which allows Hi-Semicon LED products to burn brighter, last longer, with less running costs. Typical competitive LED systems are comprised of silver and copper conductivity and phase change liquid cooling construction with an external heat sink. The emitter houses the LED die, optics and a heat sink slug used to draw heat away from the die. The conductor is made of silver and copper, which is mechanically attached to the heat sink. Hi-Semicon takes a more efficient approach to reducing operating temperature by phase change cooling system, which is thermally resistant and actually insulates the LED package from the heat sink.

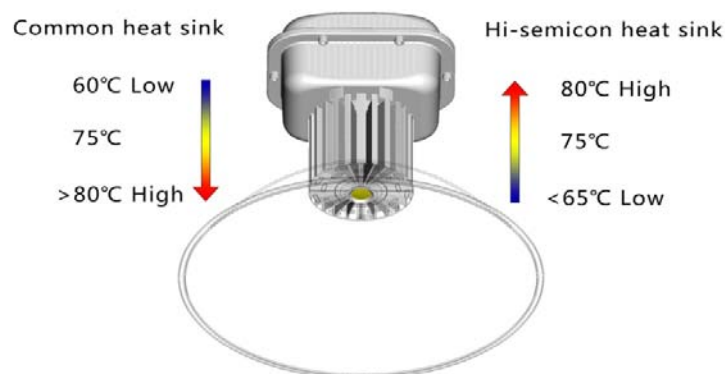

Model/Part HZ-GKD150WA-150W

Optical

Brightness	Luminous Efficacy	CCT	Emitting Angle	CRI
>10200LM	68LM/W	(5000K-6000K)	45°/120°	75

Mechanical Dimension

IP Rating	Net Weight	Dimensions
IP20	9.55kg	474.5x550x290mm(120°) 420x651.9x290mm(45°)

Electrical

Input Voltage	Power Consumption	Power Factor
85-295V 50-60Hz	150W±10%	0.95

Operating Conditions

Operating Ambient Temperature
-30°C to +70°

MECHANICAL DIMENSION DRAWING (45° reflector)

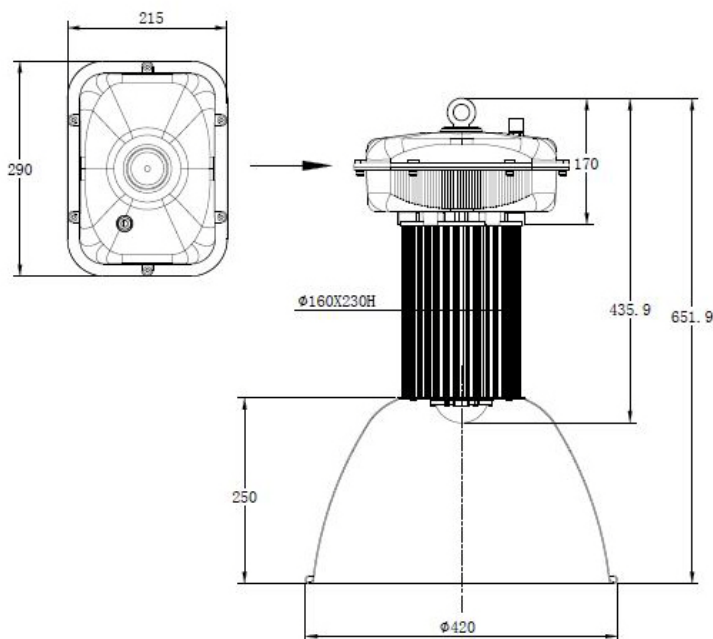

Photometric Report 45 degree reflector

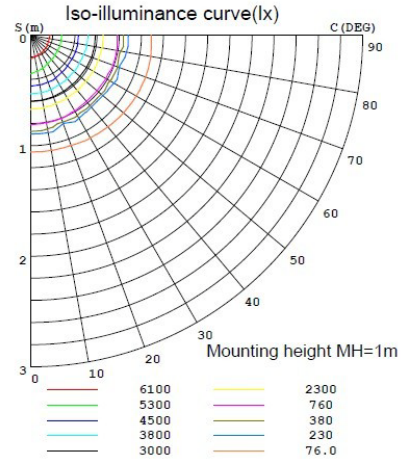
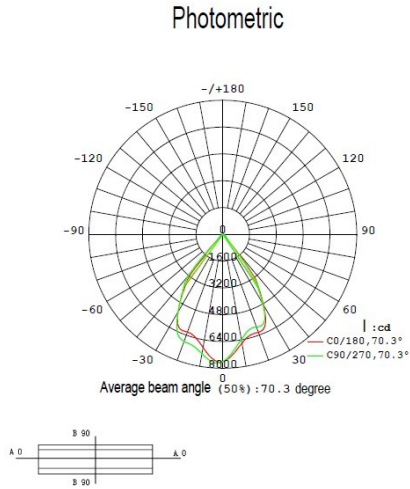

120 degree reflector

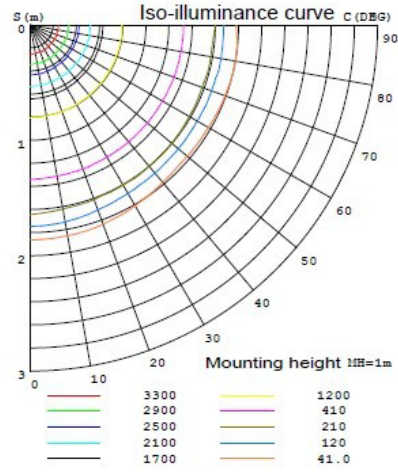
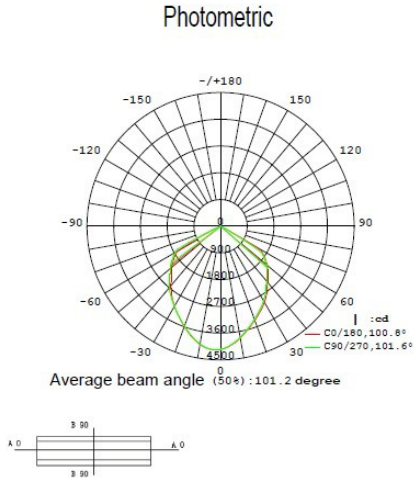

Illuminance Curve

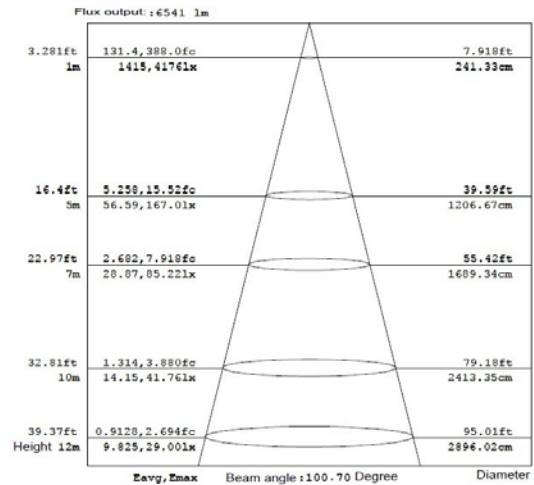
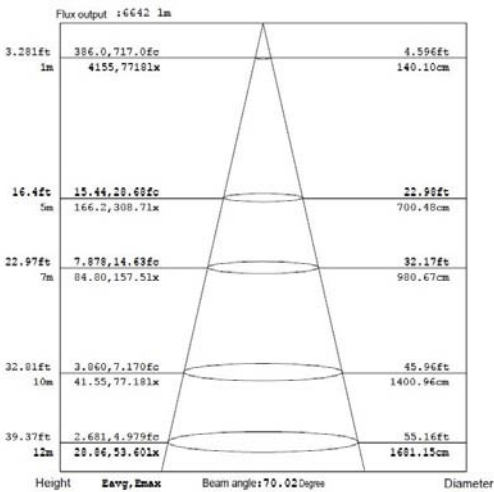

fitting type	POWER Consumption per fitting (kw)	Hours used per Day	Days used per week	weeks used per year	number of fittings	Power used per year (kWh)	power cost (cents per kWh)	Power cost per year (dollars)	Power cost saved per year compared to 400W Mercury Vapour fitting
400W Mercury Vapour high Bay	0.475	12	5	50	50	71250	\$0.22	\$15,675.00	
LED 120W High Bay	0.120	12	5	50	50	18000	\$0.22	\$3,960.00	\$11,715.00

fitting type	POWER Consumption per fitting (kw)	Hours used per Day	Days used per week	weeks used per year	number of fittings	Power used per year (kWh)	power cost (cents per kWh)	Power cost per year (dollars)	Power cost saved per year compared to 400W Mercury Vapour fitting
400W Mercury Vapour high Bay	0.475	12	5	50	50	71250	\$0.24	\$17,100.00	
LED 120W High Bay	0.120	12	5	50	50	18000	\$0.24	\$4,320.00	\$12,780.00

fitting type	POWER Consumption per fitting (kw)	Hours used per Day	Days used per week	weeks used per year	number of fittings	Power used per year (kWh)	power cost (cents per kWh)	Power cost per year (dollars)	Power cost saved per year compared to 400W Mercury Vapour fitting
400W Mercury Vapour high Bay	0.475	12	5	50	50	71250	\$0.22	\$15,675.00	
LED 150W High Bay	0.150	12	5	50	50	22500	\$0.22	\$4,950.00	\$10,725.00

fitting type	POWER Consumption per fitting (kw)	Hours used per Day	Days used per week	weeks used per year	number of fittings	Power used per year (kWh)	power cost (cents per kWh)	Power cost per year (dollars)	Power cost saved per year compared to 400W Mercury Vapour fitting
400W Mercury Vapour high Bay	0.475	12	5	50	50	71250	\$0.24	\$17,100.00	
LED 150W High Bay	0.150	12	5	50	50	22500	\$0.24	\$5,400.00	\$11,700.00

Case study images ACE GUTTERS Pty Ltd Mortdale NSW



A DIVISION OF ACE GUTTERS

ABN 49 001 885 276

69 Boundary Rd Mortdale NSW 2223 | Ph: 02 9584 4767 | Fax: 02 9584 4780

sales@hisemiconaustralia.com.au | www.hisemiconaustralia.com.au

